

Air valve(5/2 way, 5/3 way)

4A300 Series



Specification

Model	4A310-08 4A320-08	4A330C-08 4A330E-08 4A330P-08	4A310-10 4A320-10	4A330C-10 4A330E-10 4A330P-10
Fluid	Air(to be filtered by 40 μm filter element)			
Acting	Exterior control			
Port size [Note1]	In=Out=Exhaust=1/4"		In=Out=3/8" Exhaust=1/4"	
Orifice size	25.0mm ² (Cv=1.40)	18.0mm ² (Cv=1.00)	30.0mm ² (Cv=1.68)	18.0mm ² (Cv=1.00)
Valve type	5 port 2 position	5 port 3 position	5 port 2 position	5 port 3 position
Operating pressure	0.15~0.8MPa(21~114psi)			
Proof pressure	1.2MPa(175psi)			
Temperature	-20~70°C			
Material of body	Aluminum alloy			
Lubrication [Note2]	Not required			
Max. frequency [Note3]	4 cycle/sec	3 cycle/sec	4 cycle/sec	3 cycle/sec
Weight (g)	4A310-08:275 4A320-08:365	505	4A310-10:275 4A320-10:365	505

[Note1] G thread is available.

[Note2] Once lubricated air is used, continue with same medium to optimise valve life span. Lubricants like ISO VG32 or equivalent are recommended.

[Note3] The maximum actuation frequency of no-load state.

Symbol

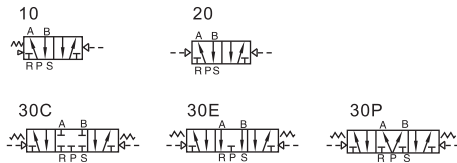

Product feature

1. Structure in sliding column mode: good tightness and sensitive reaction.
2. Three position air valves have three kinds of central function for your choice.
3. Double air control valves have memory function.
4. Internal hole adopts special processing technology which has little attrition friction, low start pressure and long service life.
5. No need to add oil for lubrication.
6. Integrate with the manifold to save installation space.

Ordering code

4A 3 10 10 G



① Model	② Code	③ Valve type	④ Port size	⑤ Thread type
4A: Air Valve(5/2, 5/3 way)	3: 300 Series	10: Single air control 5/2 way 20: Double air control 5/2 way 30C: Double air control 5/3 way closed center 30E: Double air control 5/3 way exhaust center 30P: Double air control 5/3 way pressure center	08: 1/4" 10: 3/8"	G: G

Please refer to 77 for manifold specification and the order way.

Flow chart

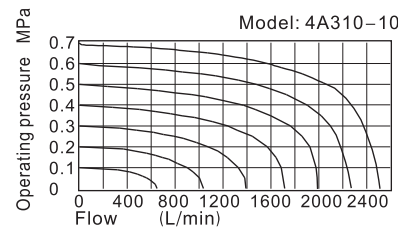
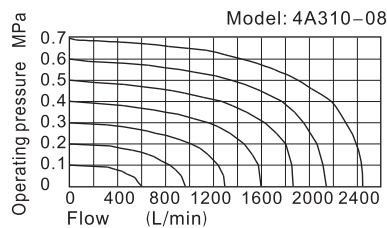

Air valve(5/2 way, 5/3 way)

4A300 Series

Inner structure

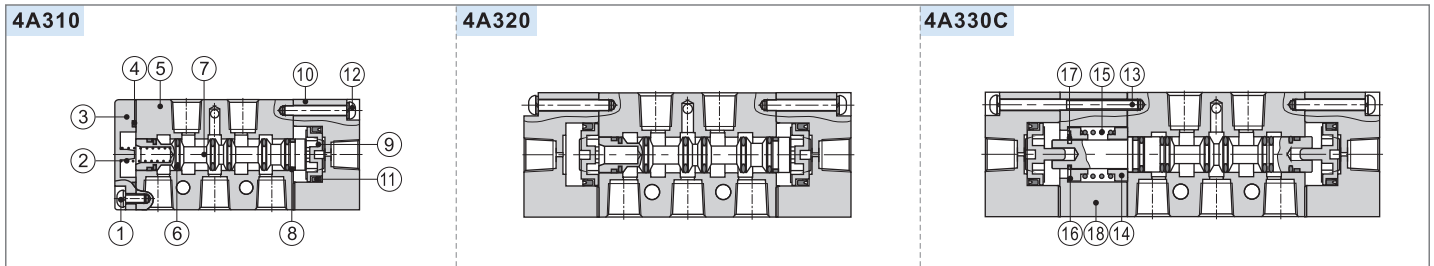

No.	Item	No.	Item	No.	Item	No.	Item	No.	Item	No.	Item	No.	Item	No.	Item	No.	Item
1	Screw	3	Bottom cover	5	Body	7	Spool	9	Piston	11	O-ring	13	Screw	15	Return Spring	17	E Clip
2	Spring	4	Bottom cover gasket	6	O-ring	8	Wear ring	10	Pilot body	12	Screw	14	Spring holder	16	Spring holder	18	Side cover

Dimension

4A310

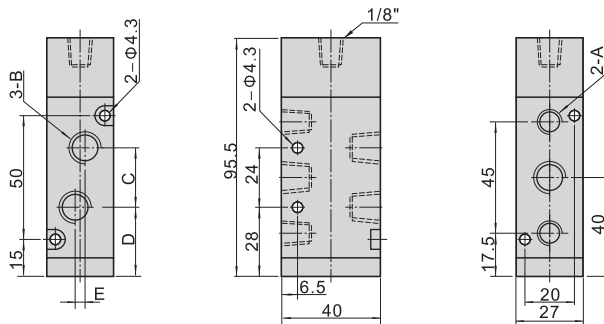

Model\Item	A	B	C	D	E
4A310-08	1/4"	1/4"	22	29	0
4A310-10	1/4"	3/8"	24	28	4

4A320

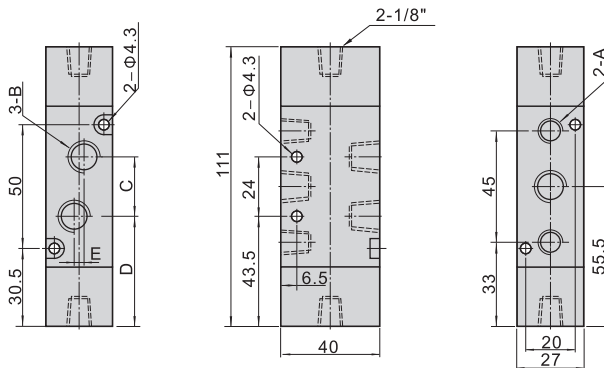

Model\Item	A	B	C	D	E
4A320-08	1/4"	1/4"	22	44.5	0
4A320-10	1/4"	3/8"	24	43.5	4

4A330

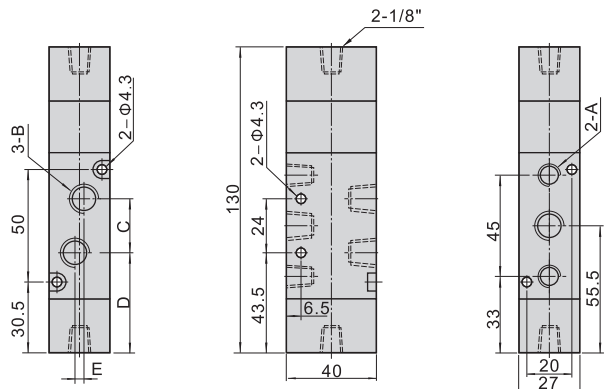

Model\Item	A	B	C	D	E
4A330-08	1/4"	1/4"	22	44.5	0
4A330-10	1/4"	3/8"	24	43.5	4

