

ISO Standard air valve(5/2 way, 5/3 way)

EAV200, 300, 400, 600 Series



Specification

Model	200 Series	300 Series	400 Series	600 Series
Orifice size(Cv) mm ²	32(Cv=1.8)	42(Cv=2.32)	69(Cv=3.85)	108(Cv=6.0)
Fluid	Air(to be filtered by 40 μm filter element)			
Acting	Extend pilot			
Lubrication [Note1]	Not required			
Operating Pressure	Single air control	0.2~1.0MPa(2~10bar)(29~145psi)		
	Double air control	-0.09~1.0MPa(-0.9~10bar)(-13~145psi)		
Control pressure(external pilot)	0.2~1.0MPa(2~10bar)(29~145psi)			
Proof pressure	1.5MPa(15bar)(215psi)			
Temperature	-20~70℃			
Port size(manifold) [Note2]	1/4"	3/8"	1/2"	3/4"
Port size(end plate)	3/8"	1/2"	3/4"	1"
Installation size	ISO 5599-1 standard			

Symbol

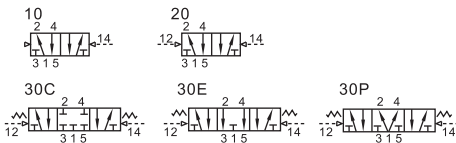

[Note1] Once lubricated air is used, continue with same medium to optimise valve life span. Lubricants like ISO VG32 or equivalent are recommended.

[Note2] G thread is available.

Product feature

1. Succinct appearance and compact conformation.
2. The installation size conforms to ISO 5599/1 standard.
3. Because of the special seals, the feature are large flow rate and long lifetime.
4. External pilot, can be used without electrical.
5. You need install the valve together with the sub-base. There are individual and manifold sub-base.
6. There are various connection and installation method for manifold. It is easy to use.
7. The manifold of 200\300\400 series have the function of exhaust throttling, so no need to connect another throttle valve.
8. Because of be used external pilot, the working pressure of double air control valve can be zero or vacuum.

Ordering code

Ordering code of manifold					
ESV 20 1M G □ □					
① Model	② Code	③ Manifold type	④ Thread type	⑤ External pilot port type	⑥ Port position type
ESV: ISO standard solenoid valve	20: 200 Series 30: 300 Series 40: 400 Series 60: 600 Series	1M: Individual sub-base 	G: G	Blank: Individual pilot port	Blank: Side port B: Bottom Port
		2M: Manifold sub-base 		Blank: Individual pilot port W: Centralized pilot port	Blank: Left side port R: Right side port B: Bottom Port
		3M: End plate kit 		No this code	No this code
	4M: Side port block 	No this code		Blank: Left side port R: Right side port	
	60: 600 Series				

Note: 1. For the same model, the port size of the end-plate is bigger than the sub-base (For example ESV202M, the port size of sub-base is 1/4" , and the port size of end plate is 3/8").

2. Only individual pilot port is available for individual sub-base.
3. The manifold sub-base must be used with end plate kit, individual pilot port and centralized pilot port can be mixed.
4. 600 series individual sub-base only has side port, 600 series manifold sub-base only has individual pilot port and bottom port.
5. Only 600 series have side port block.

ISO Standard air valve(5/2 way, 5/3 way)

EAV200, 300, 400, 600 Series

Ordering code

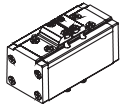
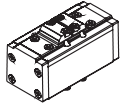
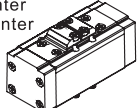
Ordering code of valve		
EAV 2 10		
1 2 3		
① Model	② Code	③ Valve type
EAV: ISO standard air valve	2: 200 Series 3: 300 Series 4: 400 Series 6: 600 Series	10: Single air control 5/2 way 
		20: Double air control 5/2 way 
		30C: Double air control 5/2 way closed center 30E: Double air control 5/2 way exhaust center 30P: Double air control 5/2 way pressure center 

Ordering code of accessories

P-ESV200M R2		
1 2 3		
① Accessories code	② Code	③ Accessories type
P: Unit accessories	ESV200M: 200 Series manifold ESV300M: 300 Series manifold ESV400M: 400 Series manifold ESV600M: 600 Series manifold	R2: Blanking plate

Ordering code of cover plate

P-EAV210 R1		
1 2 3		
① Accessories code	② Adapt production	③ Accessories type
P: Unit accessories		R1: Cover plate  With screw

Note: 600 series have not cover plate.

Inner structure

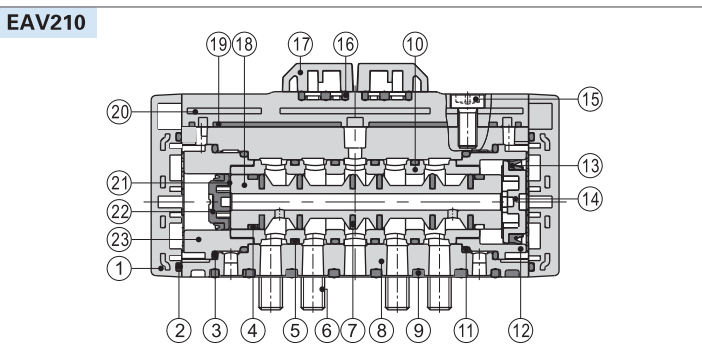

NO.	Item	NO.	Item	NO.	Item
1	Bottom cover	9	Gasket	17	Cover plate
2	O-ring	10	Spacer	18	Spool
3	O-ring	11	O-ring	19	Upper cover gasket
4	Wear ring	12	Big piston sheath	20	Upper cover
5	O-ring	13	Big piston O-ring	21	Small piston
6	Screw	14	Big piston	22	Small piston O-ring
7	O-ring	15	Screw	23	Small piston sheath
8	Body	16	Gasket		



ISO Standard air valve(5/2 way, 5/3 way)

EAV200, 300, 400, 600 Series

Flow chart

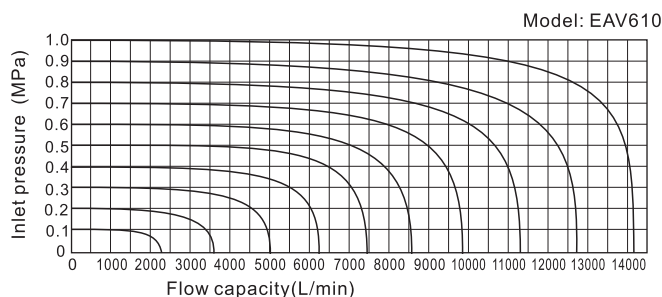
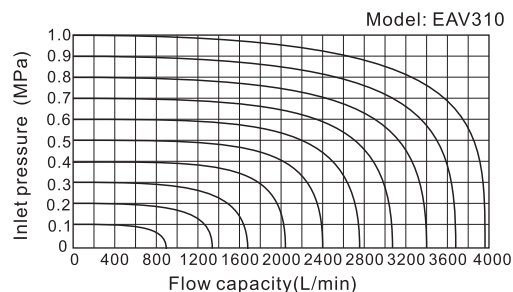
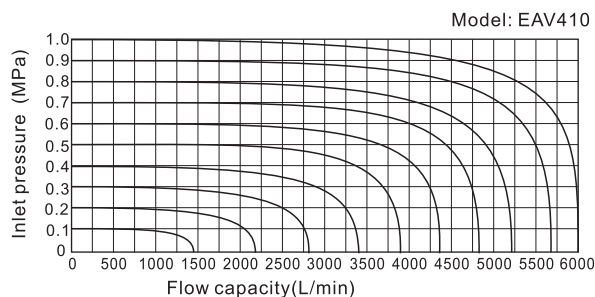
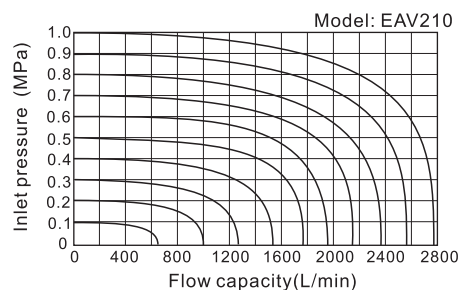

Installation and operation(For 200, 300, 400 series)

1. How to turn ESV series solenoid valve to EAV series air control valve

1.1. To turn ESV series solenoid valve (except 600 series) to EAV series air control valve, you must order cover plate first (the ordering code is P-EAV210-R1), then replace the coil unit and the pilot body with cover plate. The different gasket mounting can create different EAV air valve type as shown below.

1.2. Single solenoid valve turn to single air control valve:

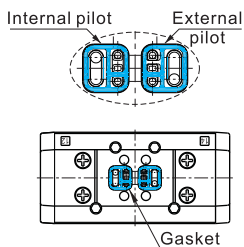

- A) Unload the cover plate of "12" end, mounted the gasket as internal pilot, then mounted the cover plate and screw.
- B) Unload the pilot valve of "14" end, mounted the gasket as external pilot, and replace the pilot valve with the cover plate, then mounted screw.
- C) After above two steps finished, single solenoid valve has been turned to single air control valve.

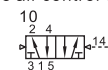

1.3. Double solenoid valve turn to double air control valve:

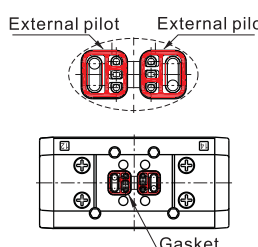

- A) Unload the two pilot valves of "12", "14" ends, mounted the two gaskets as external pilot and replace the pilot valve with the cover plate, then mounted screw.
- B) After above step finished, double solenoid valve has been turned to single air control valve.

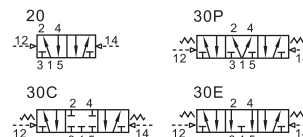

2. The classification and selection of the parallel manifold sub-base

2.1. According to the direction of pilot air supply, we can divide the sub-base manifold into two types: the individual pilot and centralized pilot.

2.2. If you select the individual pilot, the fitting must be connected to the individual pilot ports.

If you select the centralized pilot type, the fitting must be connected to the centralized pilot ports.

2.3. If you use parallel manifold, all of the manifold must be used the same pilot type: such as, all of them are the individual pilot type, or all of them are the centralized pilot type.

*Note: Only when you use the external pilot type, you can select the individual pilot or centralized pilot.

When you use the internal pilot type, the pilot ports on the manifold are ineffective.

3. The position and specification of the parallel manifold sub-base:

The diagram of manifold sub-base	Port status of different manifold sub-base					
	Port name Ordering code	Left side port	Right side port	Bottom port	Centralized pilot port	Individual pilot port
	ESV202MG	Use	Unused	Unused	Unused	Use
	ESV202MGR	Unused	Use	Unused	Unused	Use
	ESV202MGB	Unused	Unused	Use	Unused	Use
	ESV202MGW	Use	Unused	Unused	Use	Unused
	ESV202MGWR	Unused	Use	Unused	Use	Unused
	ESV202MGWB	Unused	Unused	Use	Use	Unused

Note: Please seal the bottom port by plug, when it is unused.
The above list is an example of 200M series' ordering code, the other series is follow the same pattern, only need to change the series code.

4. Exhaust throttle function

4.1. The manifold has exhaust throttle function, the below picture shows the position of the exhaust throttle orifices on each side.

4.2. Use allen key to adjust the screw.

4.3. Rotate the screw clockwise to reduce the exhaust orifice, rotate the screw counter-clockwise to enlarge the exhaust orifice.

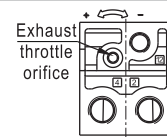
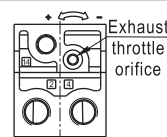

Manifold right side

Manifold left side

ISO Standard air valve(5/2 way, 5/3 way)

EAV200, 300, 400, 600 Series

Dimensions of valves

EAV210\EAV220

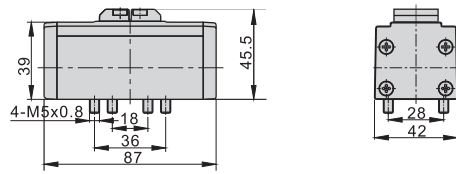

EAV230

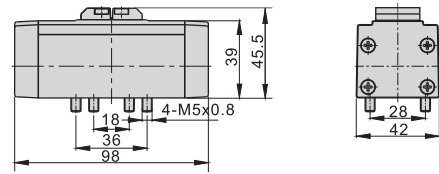

EAV310\EAV320

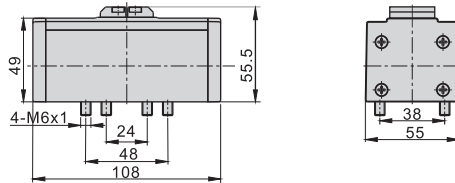

EAV330

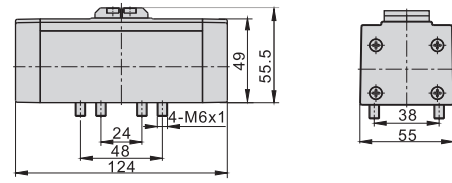

EAV410\EAV420

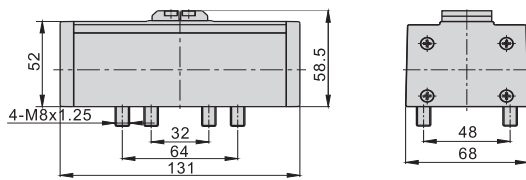

EAV430

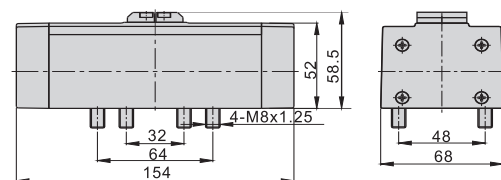

EAV610\EAV620\EAV630

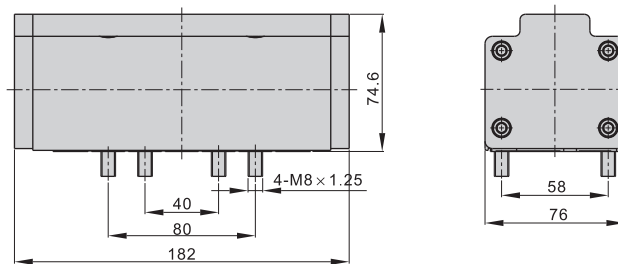

Dimensions of manifold

The dimensions of manifold are the same as ESV series's, please refer to ESV series's dimensions for details.



ISO Standard air valve(5/2 way, 5/3 way)

EAV200, 300, 400, 600 Series

Valves used with manifolds and their dimensions

1. EAV series valve must be used with the manifolds, the details are below:

Manifolds	Valves	
	EAV210\EAV220 EAV310\EAV320 EAV410\EAV420 EAV610\EAV620	EAV230 EAV330 EAV430 EAV630
ESV201M	EAV210\EAV220+ESV201M	EAV230+ESV201M
ESV301M	EAV310\EAV320+ESV301M	EAV330+ESV301M
ESV401M	EAV410\EAV420+ESV401M	EAV430+ESV401M
ESV601M	EAV610\EAV620+ESV601M	EAV630+ESV601M
ESV202M+ESV203M	EAV210\EAV220+ESV202M+ESV203M	EAV230+ESV202M+ESV203M
ESV302M+ESV303M	EAV310\EAV320+ESV302M+ESV303M	EAV330+ESV302M+ESV303M
ESV402M+ESV403M	EAV410\EAV420+ESV402M+ESV403M	EAV430+ESV402M+ESV403M
ESV602M+ESV603M+ESV604M	EAV610\EAV620+ESV602M+ESV603M+ESV604M	EAV630+ESV602M+ESV603M+ESV604M

2. The dimensions of valve with manifolds

EAV210/EAV220+ESV201M

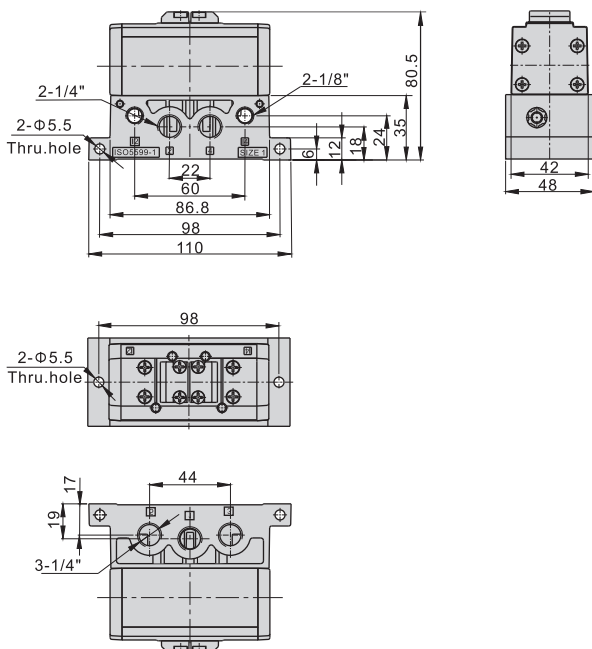

EAV230+ESV201M

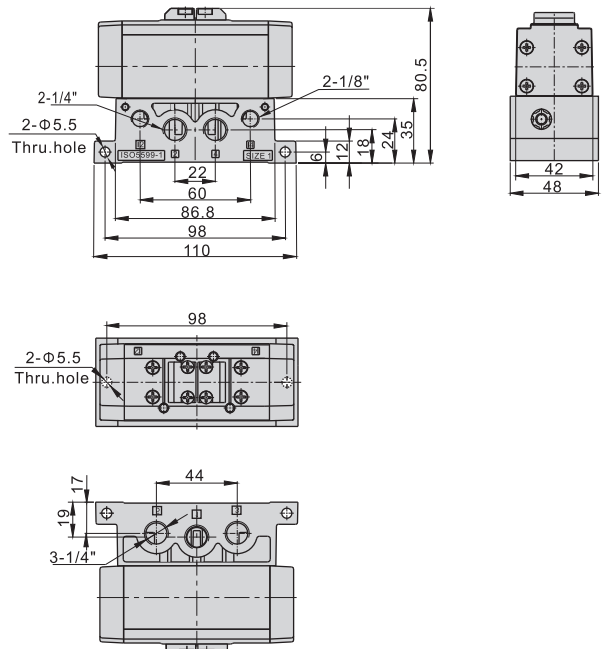

ISO Standard air valve (5/2 way, 5/3 way)

EAV200, 300, 400, 600 Series

EAV210/EAV220+ESV202M+ESV203M

Note: "n" means the number of stations.

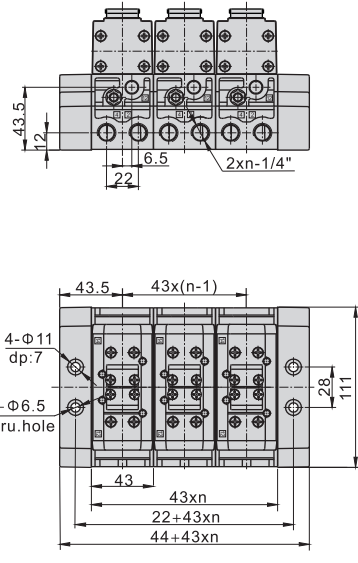

EAV230+ESV202M+ESV203M

Note: "n" means the number of stations.

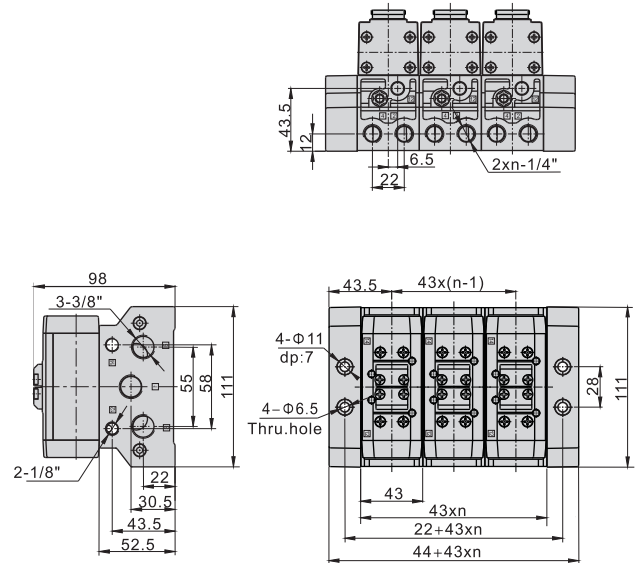

EAV310/EAV320+ESV301M

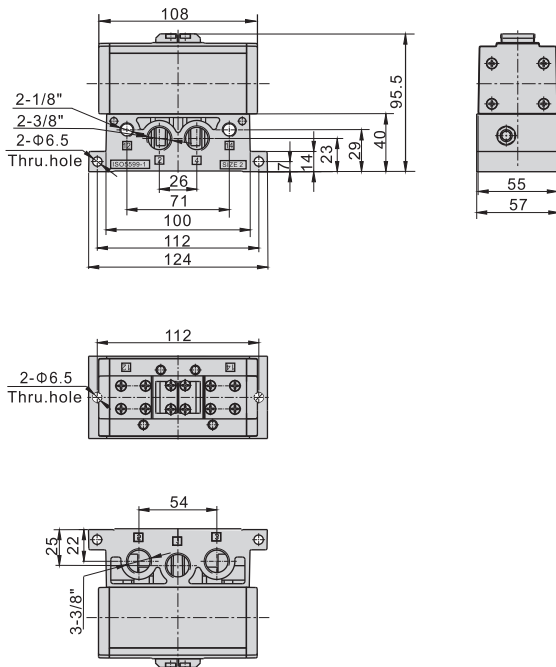

EAV330+ESV301M

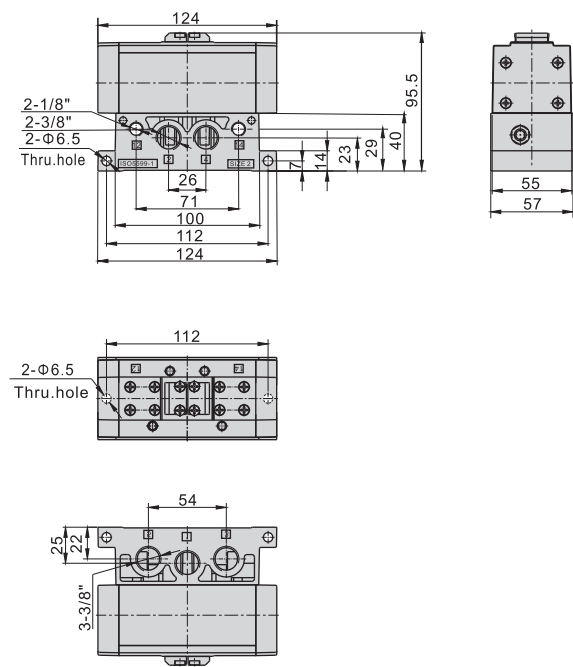

ISO Standard air valve (5/2 way, 5/3 way)

EAV200, 300, 400, 600 Series

EAV310/EAV320+ESV302M+ESV303M

Note: "n" means the number of stations.

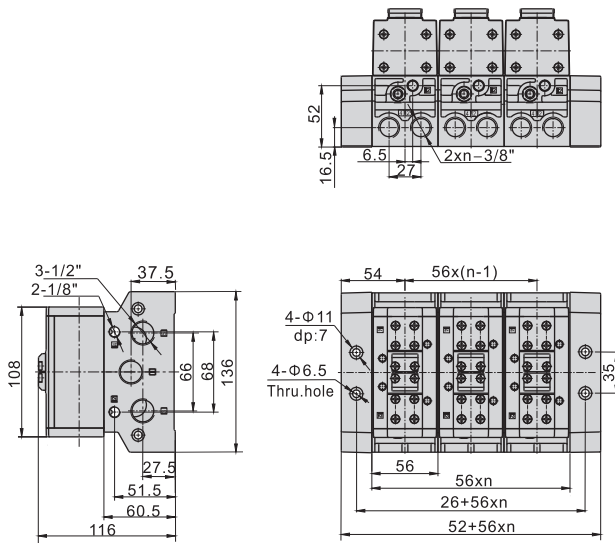

EAV330+ESV302M+ESV303M

Note: "n" means the number of stations.

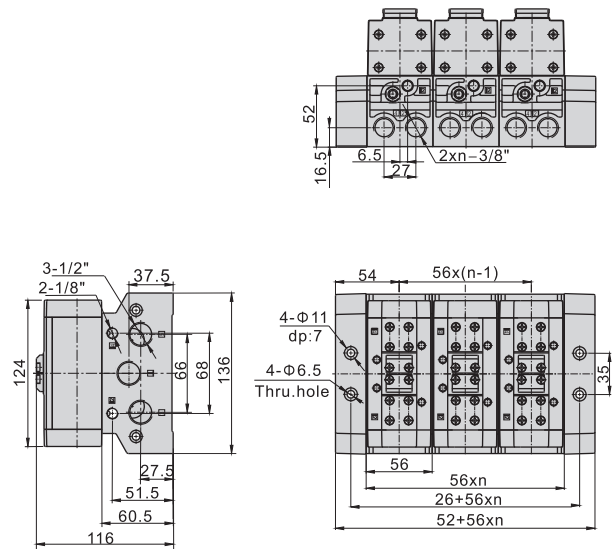

EAV410/EAV420+ESV401M

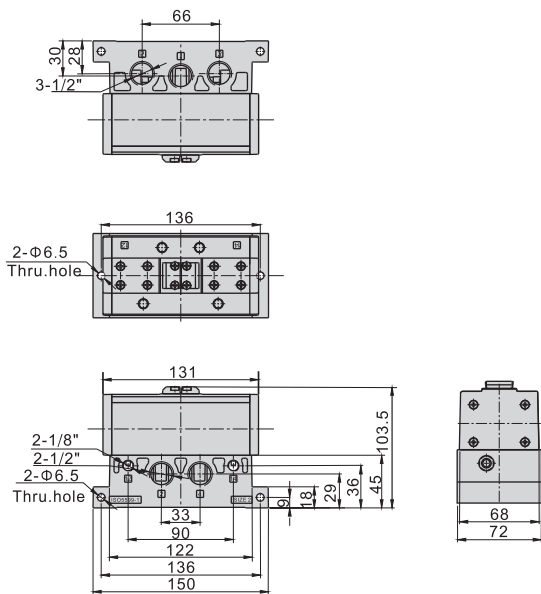

EAV430+ESV401M

